

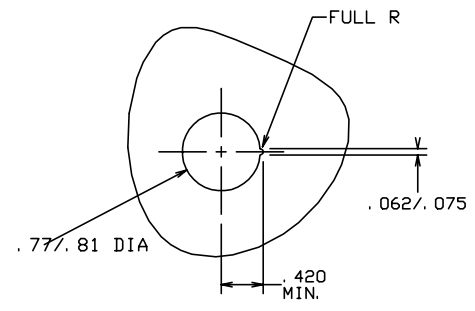

THE INFORMATION AND DESIGN HEREIN WAS ORIGINATED BY AND IS THE PROPERTY OF SKYLOCK INDUSTRIES INCORPORATED. SKYLOCK INDUSTRIES INCORPORATED RESERVES ALL PATENT, PROPRIETARY, DESIGN MANUFACTURING, REPRODUCTION, USE AND SALES RIGHTS THERE TO, AND TO ANY ARTICLE DISCLOSED THEREIN EXCEPT TO THE EXTENT RIGHTS ARE EXPRESSLY GRANTED TO OTHERS. THE FOREGOING DOES NOT APPLY TO VENDOR PROPRIETARY PARTS.

REVISIONS				
ZONE	LTR	DESCRIPTION	DATE	APPROVED
	NC	PRODUCTION RELEASE	12-14-91	T. CSIK

- NOTES: UNLESS OTHERWISE SPECIFIED.
1. REMOVE ALL BURRS AND BREAK SHARP EDGES.
 2. MAT'L: ALL COMPONENTS; BRASS.
 3. FINISH: BRIGHT CHROME PLATE.
 4. FUNCTION: THIS IS A FREE FLOW TYPE FAUCET AND IS DESIGNED ONLY TO OPERATE WITH A CUSTOMER SUPPLIED WATER REGULATOR/SHUTOFF VALVE.

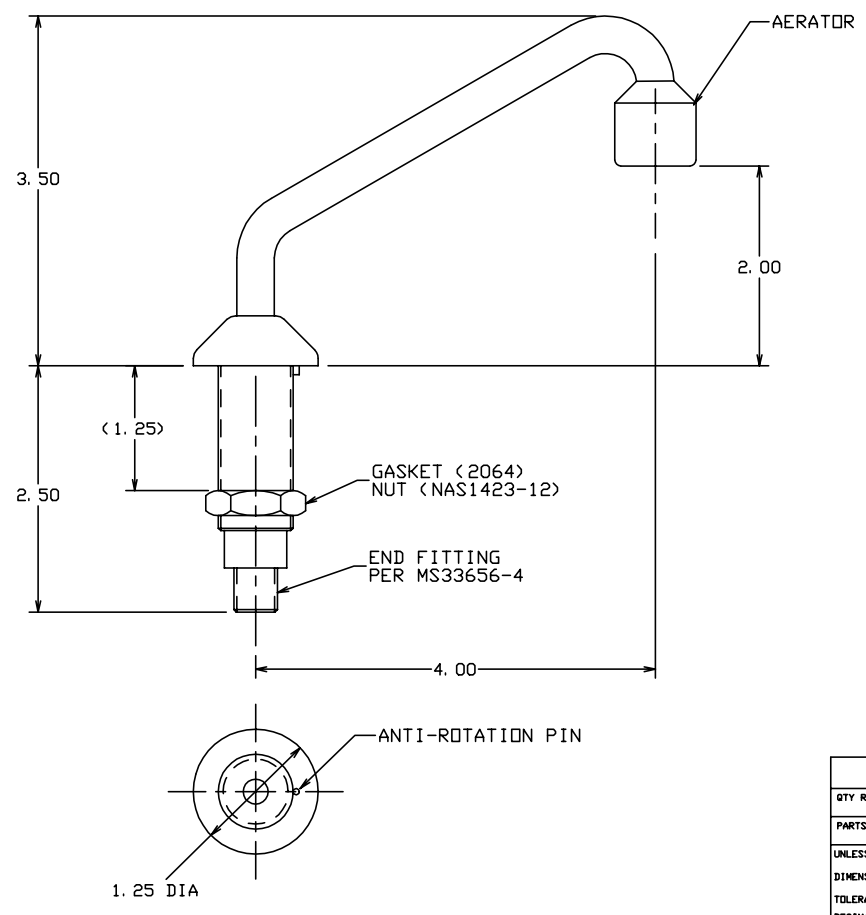

PANEL CUTOUT

-1 FAUCET ASSY					
QTY REQD	PART NO.	DESCRIPTION	MATERIAL	SIZE	SPECIFICATION
PARTS LIST					
UNLESS OTHERWISE SPECIFIED		DRAWN BY T. CSIK	12-9-91	 SKYLOCK INDUSTRIES INCORPORATED MONROVIA CALIFORNIA U. S. A.	
DIMENSIONS ARE IN INCHES		CHECKED			
TOLERANCES ON		ENGINEER			
DECIMALS ANGLES DRILLED HOLES		PROJECT			
.X ± .1 ± 0° 30' AND 10387		APPROVAL T. CSIK	12-9-91	FAUCET ASSY	
.XX ± .03		APPROVAL			
.XXX ± .010					
DO NOT SCALE THIS DRAWING				SIZE	CODE IDENT. NO. DRAWING NO.
MATERIAL - FINISH		USED ON		C	51941 90059
NEXT ASSY					REV. NC
FINAL ASSY				SCALE 1: 1	WT. SHEET 1 OF 1