

THE INFORMATION AND DESIGN HEREIN WAS ORIGINATED BY AND IS THE PROPERTY OF SKYLOCK INDUSTRIES INCORPORATED. SKYLOCK INDUSTRIES INCORPORATED RESERVES ALL PATENT, PROPRIETARY, DESIGN MANUFACTURING, REPRODUCTION, USE AND SALES RIGHTS THERE TO, AND TO ANY ARTICLE DISCLOSED THEREIN EXCEPT TO THE EXTENT RIGHTS ARE EXPRESSLY GRANTED TO OTHERS. THE FOREGOING DOES NOT APPLY TO VENDOR PROPRIETARY PARTS.

REVISIONS				
ZONE	LTR	DESCRIPTION	DATE	APPROVED
	NC	PRODUCTION RELEASE	3-20-96	T. CSIK

- NOTES: UNLESS OTHERWISE SPECIFIED.
1. REMOVE ALL BURRS AND BREAK SHARP EDGES.
 2. MAT'L: ALL COMPONENTS; 300 SERIES CRES.
 3. FINISH: SATIN BRUSH, AND PASSIVATE PER QQ-P-35.
 4. HOLDER FLAP IS SPRING LOADED CLOSED.

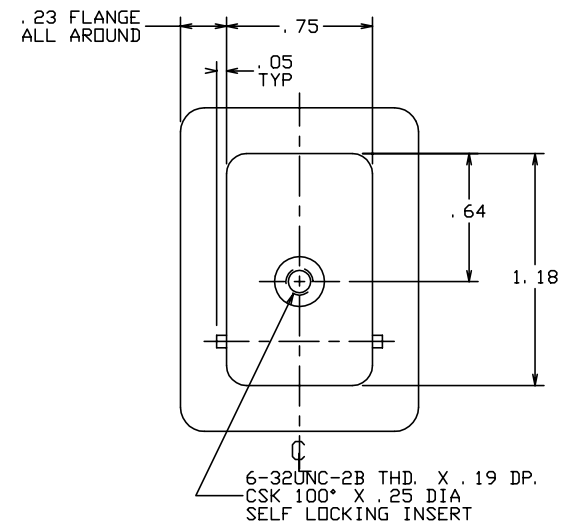
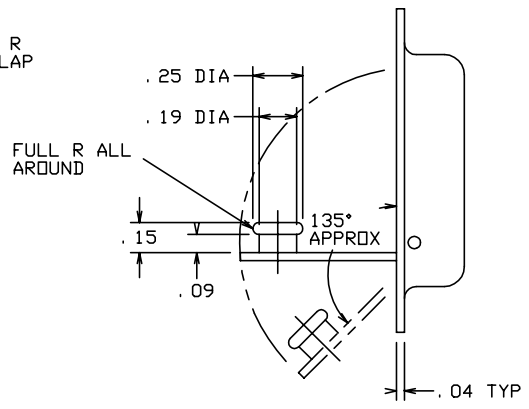
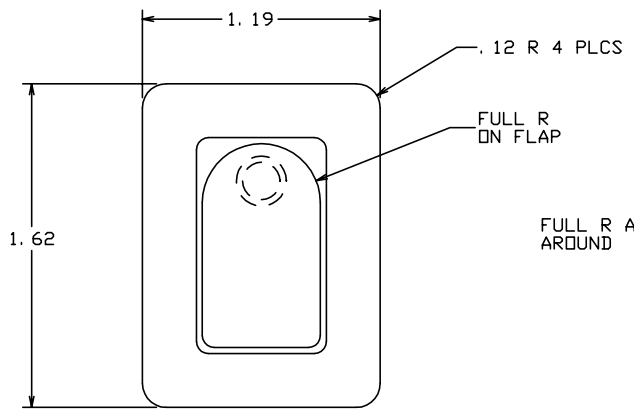

-1		HOLDER, I. V. BAG		
PART NO.	DESCRIPTION	MATERIAL SIZE SPECIFICATION		
PARTS LIST				
UNLESS OTHERWISE SPECIFIED		DRAWN BY	T. CSIK	3-20-96
DIMENSIONS ARE IN INCHES		CHECKED		
TOLERANCES ON		ENGINEER		
DECIMALS ANGLES DRILLED HOLES		PROJECT		
.X ± .1 ± 0° 30' AND 10387		APPROVAL	T. CSIK	3-20-96
.XX ± .03		APPROVAL		
.XXX ± .010				
DO NOT SCALE THIS DRAWING				
MATERIAL - FINISH	USED ON	SIZE	CODE IDENT. NO.	DRAWING NO.
NEXT ASSY		C	51941	20920
FINAL ASSY		SCALE	1: 1	WT.
				SHEET 1 OF 1



HOLDER, I. V. BAG

REV. NC