

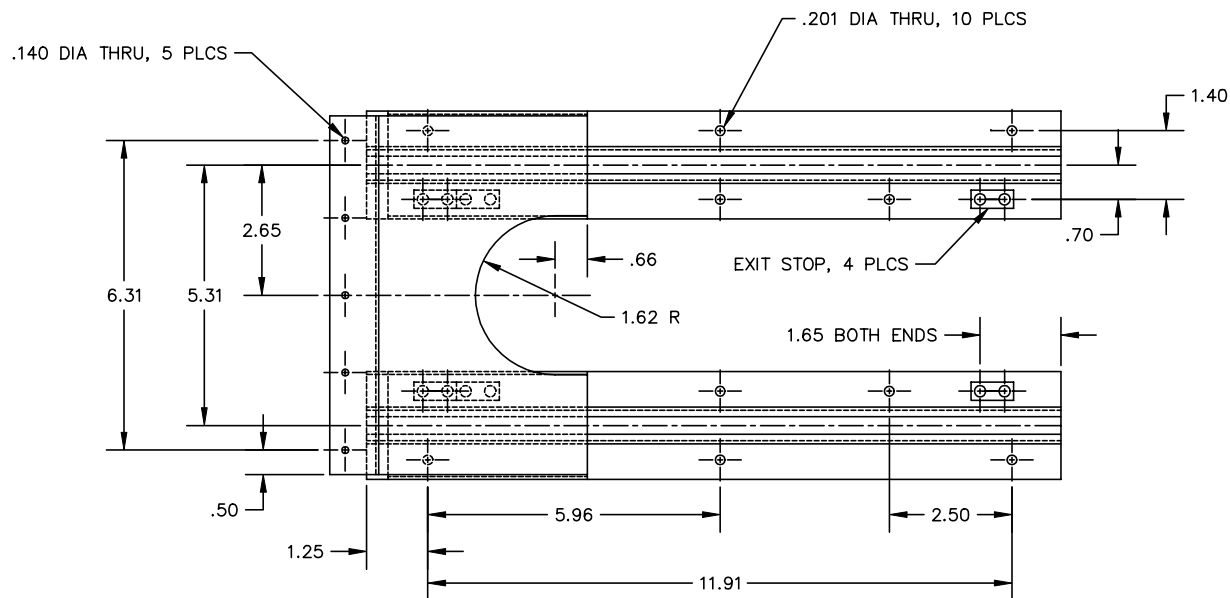
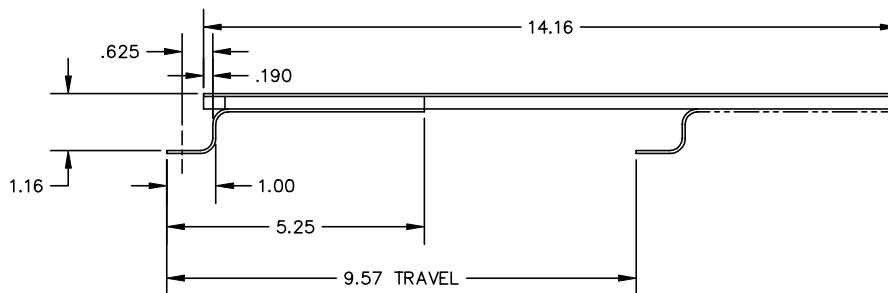

THE INFORMATION AND DESIGN HEREIN WAS ORIGINATED BY AND IS THE PROPERTY OF SKYLOCK INDUSTRIES INCORPORATED. SKYLOCK INDUSTRIES INCORPORATED RESERVES ALL PATENT, PROPRIETARY, DESIGN MANUFACTURING, REPRODUCTION, USE AND SALES RIGHTS THEREON, AND TO ANY ARTICLE DISCLOSED THEREIN EXCEPT TO THE EXTENT RIGHTS ARE EXPRESSLY GRANTED TO OTHERS. THE FOREGOING DOES NOT APPLY TO VENDOR PROPRIETARY PARTS.

REVISIONS				
ZONE	LTR.	DESCRIPTION	DATE	APPROVED
	NC	PRODUCTION RELEASE	10.18.93	SC

NOTES: UNLESS OTHERWISE SPECIFIED

1. REMOVE ALL BURRS AND SHARP EDGES
2. MAT'L: RAILS AND STOPS; 6061-T5 ALUM ALLOY;
TIE PLATE AND CHANNEL; 2024-T3 ALUM ALLOY;
ROLLER ASSY; NYLON AND CRES
3. FINISH: ALUM; CLEAR ANODIZE; CRES; PASSIVATE
4. ALL STOPS IN RAILS ATTACHED WITH MS20426AD6 RIVETS
5. STOPS IN TIE PLATE ASSY ATTACHED WITH NAS 603-6 SCREWS
6. DECORATIVE FINISH: TIE PLATE ASSY AND RAILS (EXCEPT IN SLIDE AREA)
WHITE POLYESTER POWDER COAT



-1		SLIDE ASSY			
QTY. REQ'D	PART / IDENT NO.	DESCRIPTION	MATERIAL / SPECIFICATION		ITEM NO.
UNLESS OTHERWISE SPECIFIED: DIMENSIONS ARE IN INCHES		CONTRACT NO.	 SKYLOCK INDUSTRIES INCORPORATED MONROVIA, CALIFORNIA, USA		
TOLERANCES DECIMALS .XX ±.03 ANGULAR ± 0 30' .XXX ±.010		CUSTOMER			
DO NOT SCALE DRAWING		DRAWN BY S. CSIK	DATE		
NEXT ASSY	FINAL ASSY	DESIGN	CHECK		
USED ON		DESIGN ACTIVITY	SIZE C	FSCM NO. 51941	DRAWING NO. 20866
FINISH	ACT WT	CALC WT	SCALE 1/2	RELEASE DATE 10.18.93	REV. NC
			SHEET 1	OF 1	

DRAWING NO.

SHEET OF

A