

LENGTH L DATA (LENGTH L IN SIXTEENTHS OF AN INCH)

CODE	5	6	7	8	9	10	11	12	13	14	15	16	17	18	20	22	24
L	.312	.375	.437	.500	.562	.625	.687	.750	.812	.875	.937	1.000	1.062	1.125	1.250	1.375	1.500
D MIN	.218	.295	.400	.472													

STANDOFF MATERIAL AND FINISH DATA

CODE	MATERIAL	SPEC.	FINISH	SPEC.
A	2024 OR 6061	AMS-QQ-A-200, AMS-QQ-A-225, AMS-QQ-A-250	NONE	
AA	ALUMINUM		ANODIZE	MIL-A-8625
CR	302, 303, 304 OR A-286 CRES	AMS 5513, 5516, 5636, 5637, 5638, 5639, 5640, 5641, 5647 AMS 5525, 5726, 5731, 5732, 5734, 5737 (CHEMISTRY ONLY)	PASSIVATE	AMS 2700
CRA	A-286 CRES	AMS 5525, 5726, 5731, 5732, 5734, 5737 (CHEMISTRY ONLY)	PASSIVATE	AMS 2700
T	6AL-4V TITANIUM	AMS 4911, 4928, 4965, OR 4967	NONE	

THREAD T DATA

CODE	THREAD SIZE
06	.1380-32 UNC-3B
08	.1640-32 UNC-3B
3	.1900-32 UNF-3B

MS21209 OR NAS1130 INSERT.  
INSERT INSTALLED PER MS33537.  
DRI-FILM LUBE ON INSERT PER AS5272 TY 1.  
THREAD LOCK PER NASM25027.  
STANDOFF ACCOMMODATES AS8879 UNJ THREAD SCREW.

BASEPLATE MATERIAL

CODE	MATERIAL
C	CARBON/EPOXY, 350°F CURE
E	GLASS/EPOXY, 350°F CURE
G	GLASS/EPOXY, 250°F CURE
K	GLASS/PEKK
P	GLASS/PEEK
U	GLASS/PEI, 30% GLASS
UC	CARBON/PEI, 30% CARBON
V	GLASS/PEI, 40% GLASS
VC	CARBON/PEI, 40% CARBON
W	GLASS/PEI, 30% GLASS, LOW HEAT RELEASE
WC	CARBON/PEI, 30% CARBON, LOW HEAT RELEASE

STANDOFF STRAIGHT WITHIN .004 INCH PER INCH OF LENGTH.  
PITCH DIA CONCENTRIC WITH BASE O.D. WITHIN .020 FIM.  
PITCH DIA PERPENDICULAR TO BASE WITHIN ±1 DEG.

DISPOSABLE PRESSURE SENSITIVE ADHESIVE FIXTURE  
HOLDS STANDOFF WHILE ADHESIVE CURES.

EXAMPLE PART NUMBER

CB4001 G 3 CRA 12 H P 750

OPTIONAL TRIMMED BASE - .750  
OPTIONAL MIL-PRF-85582 EPOXY PRIMER ON BASEPLATE  
OPTIONAL INSPECTION HOLE  
STANDOFF LENGTH L - .750  
STANDOFF MATERIAL - A-286 CRES  
THREAD SIZE T - .1900-32 UNF-3B  
BASEPLATE MATERIAL - GLASS/EPOXY, 250°F CURE  
BASIC PART NUMBER

UNLESS OTHERWISE SPECIFIED, ALL DIMENSIONS ARE IN INCHES AND TOLERANCES ARE AS SHOWN BELOW. DIMENSIONAL TOLERANCES AND SYMBOLS PER ANSI Y14.5M-1982.

PROPRIETARY PARTS SHOWN IN THIS DRAWING ARE THE SUBJECT OF ISSUED UNITED STATES AND FOREIGN PATENTS AND PATENTS PENDING. UNAUTHORIZED REPRODUCTION AND/OR DISTRIBUTION OF THIS DRAWING IS SPECIFICALLY PROHIBITED.

**CLICK BOND**

CARSON CITY  
NEVADA 89706

CAD CB4001-1

APPROVALS	DATE
DRAWN <i>DAC</i>	3MAR08
CHECKED <i>DAC/mtm</i>	3MAR08
RELEASED <i>CGH</i>	3MAR08
REVISED <i>DAC</i>	3MAR08

TITLE			
STANDOFF, LOCKING THREAD, COMPOSITE BASE			
SIZE	CAGE CODE	DWG. NO.	REV.
A	66530	CB4001	24
SCALE	1/1		3MAR08
SHEET 1 OF 2			

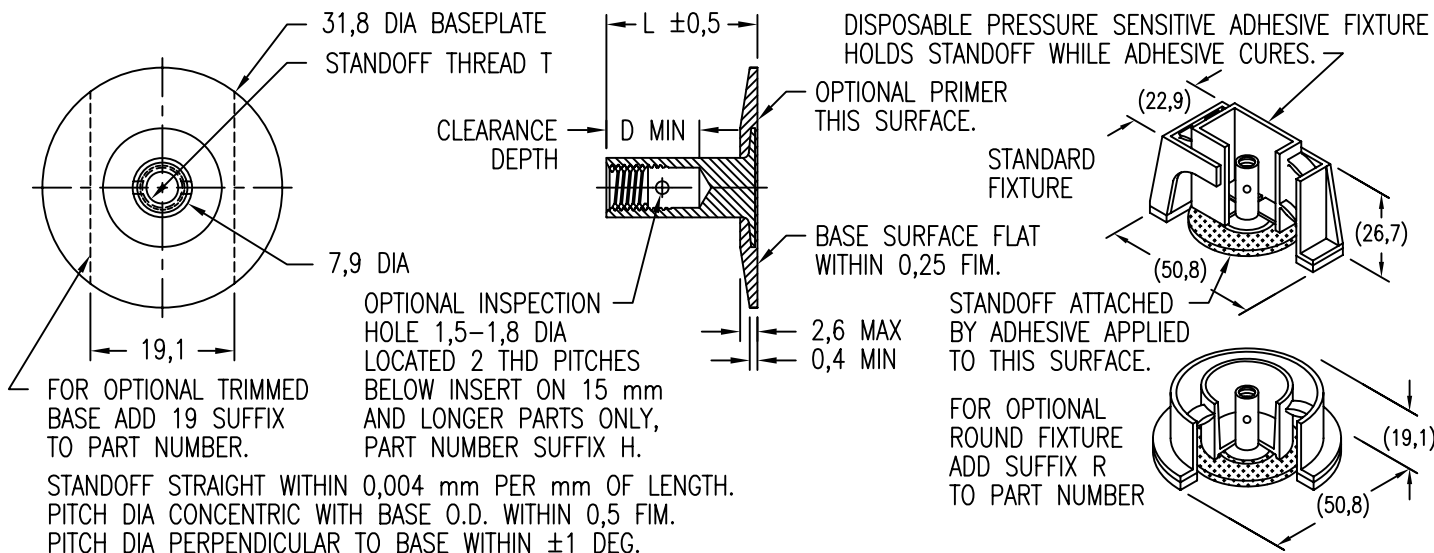

STANDOFF MATERIAL AND FINISH DATA

CODE	MATERIAL	SPEC.	FINISH	SPEC.
A	2024 OR 6061	AMS-QQ-A-200, AMS-QQ-A-225, AMS-QQ-A-250	NONE	
AA	ALUMINUM		ANODIZE	MIL-A-8625
CR	302, 303, 304 OR A-286 CRES	AMS 5513, 5516, 5636, 5637, 5638, 5639, 5640, 5641, 5647 AMS 5525, 5726, 5731, 5732, 5734, 5737 (CHEMISTRY ONLY)	PASSIVATE	AMS 2700
CRA	A-286 CRES	AMS 5525, 5726, 5731, 5732, 5734, 5737 (CHEMISTRY ONLY)	PASSIVATE	AMS 2700
T	6AL-4V TITANIUM	AMS 4911, 4928, 4965, OR 4967	NONE	

LENGTH L DATA (LENGTH L IN MILLIMETERS)

CODE	10M	12M	15M	20M	25M	30M	35M
L	10	12	15	20	25	30	35
D MIN	7,50		12,30				

BASEPLATE MATERIAL

CODE	MATERIAL
C	CARBON/EPOXY, 177°C CURE
E	GLASS/EPOXY, 177°C CURE
G	GLASS/EPOXY, 121°C CURE
K	GLASS/PEKK
P	GLASS/PEEK
U	GLASS/PEI, 30% GLASS
UC	CARBON/PEI, 30% CARBON
V	GLASS/PEI, 40% GLASS
VC	CARBON/PEI, 40% CARBON
W	GLASS/PEI, 30% GLASS, LOW HEAT RELEASE
WC	CARBON/PEI, 30% CARBON, LOW HEAT RELEASE

THREAD T DATA

CODE	THREAD SIZE
3M	M3 X 0,5 4H5H
4M	M4 X 0,7 4H6H
5M	M5 X 0,8 4H6H

MA3330 OR EQUIVALENT INSERT.  
INSERT INSTALLED PER MA1567.  
DRI-FILM LUBE PER AS5272 TY 1.  
THREAD LOCK PER ISO2320.  
STANDOFF ACCOMMODATES  
ISO5855 MJ THREAD SCREW.

EXAMPLE PART NUMBER

CB4001 G 5M CRA 20M H P 19

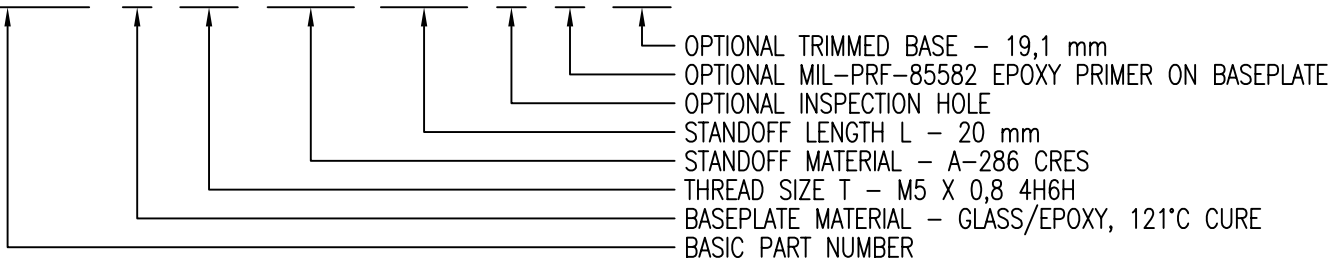

UNLESS OTHERWISE SPECIFIED, ALL DIMENSIONS ARE IN MILLIMETERS AND TOLERANCES ARE AS SHOWN BELOW. DIMENSIONAL TOLERANCES AND SYMBOLS PER ANSI Y14.5M-1982.

PROPRIETARY PARTS SHOWN IN THIS DRAWING ARE THE SUBJECT OF ISSUED UNITED STATES AND FOREIGN PATENTS AND PATENTS PENDING. UNAUTHORIZED REPRODUCTION AND/OR DISTRIBUTION OF THIS DRAWING IS SPECIFICALLY PROHIBITED.



CARSON CITY  
NEVADA 89706

CAD CB4001-2 METRIC DIMENSIONS		APPROVALS		DATE	TITLE			
ANGLES ±1°		DRAWN DAC		3MAR08	STANDOFF, LOCKING THREAD, COMPOSITE BASE			
.XX ±0,8	CHECKED DAC	3MAR08		SIZE	CAGE CODE	DWG. NO.	REV.	
.XXX ±0,25	RELEASED CGH	3MAR08		A	66530	CB4001 (METRIC)	24	
	REVISED DAC	3MAR08		SCALE	1/1	3MAR08	SHEET 2 OF 2	