

THE INFORMATION AND DESIGN HEREIN WAS ORIGINATED BY AND IS THE PROPERTY OF SKYLOCK INDUSTRIES INCORPORATED. SKYLOCK INDUSTRIES INCORPORATED RESERVES ALL PATENT, PROPRIETARY, DESIGN MANUFACTURING, REPRODUCTION, USE AND SALES RIGHTS THERE TO, AND TO ANY ARTICLE DISCLOSED THEREIN EXCEPT TO THE EXTENT RIGHTS ARE EXPRESSLY GRANTED TO OTHERS. THE FOREGOING DOES NOT APPLY TO VENDOR PROPRIETARY PARTS.

NOTES: UNLESS OTHERWISE SPECIFIED, REMOVE ALL BURRS AND SHARP CORNERS.

1. MATERIAL REF.: CASE ASSY, ACTUATOR KNOB - 6061-T6/T651 PER ASTM B-209, OR EQUIV.; INDICATOR SIGN AND WINDOW - TRANSLUCENT PLASTIC; BOLT AND ALL OTHER COMPONENTS - 300 SERIES CRES, PER AMS 5640N OR EQUIV.
2. DECORATIVE FINISH REF.: ALL VISIBLE METAL SURFACES - SATIN BUFF LENGTHWISE TO PART SURFACE.
3. PROTECTIVE FINISH REF.: ALUM. - CLEAR ANODIZE PER MIL-A-8625, TYPE II, CLASS 1, OR EQUIV. CRES PARTS- PASSIVATE PER AMS-QQ-P-35, TYPE II, OR EQUIV.
4. LETTERS TO BE CENTERED IN WINDOW.
5. LATCH IS SPRING BIASED TO THE EXTENDED OR RETRACTED POSITIONS.
6. LIGHT FROM LAVATORY SIDE ILLUMINATES INDICATOR SIGN THRU TRANSLUCENT WINDOW.
7. LATCH OPERATION: LAVATORY SIDE ACTUATOR KNOB EXTENDS AND RETRACTS BOLT. INDICATOR SIGN READS "VACANT" (OR EQUIV.) WHEN BOLT IS RETRACTED, AND "OCCUPIED" (OR EQUIV.) WHEN BOLT IS EXTENDED. FOR "AISLE SIDE EMERGENCY ACCESS, LIFT "LAVATORY" SIGN AND MOVE KNOB.
8. OPTIONAL: SATIN BRUSH LENGTHWISE TO PART SURFACE CRES ESCUTCHEONS (ATTACHED TO DOOR BY TABS).
9. PER FAR 45.15. PARTS WILL IDENTIFIED WITH:
 1. FAA-PMA.
 2. SKYLOCK IND. INC.
 3. PART NO.
 4. AIRCRAFT ELIGIBILITY.

INDICATOR SIGN SHOWS UNLOCKED/LOCKED SYMBOLGY AS SHOWN BELOW:

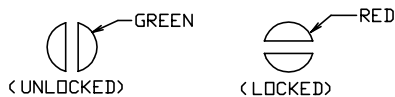

REVISIONS				
ZONE	LTR	DESCRIPTION	DATE	APPROVED
	NC	PRODUCTION RELEASE	10-3-77	J. E. E.
	A	ADDED -19 & -152	1-15-93	S. CSIK
	B	RECRAWN, ADDED -21.	2-29-96	T. CSIK
	C	SEE ECN C	12/31/98	T. CSIK
	D	ADDED -23/-24	2-23-00	T. CSIK

3/4"		-152	EMERGENCY UNLOCK ASSY (NO LETTERING)			
3/4"		-150	EMERGENCY UNLOCK ASSY			
3/4"		-51	KNOB & ESCUTCHEON KIT			
1"		-50	EMERGENCY UNLOCK ASSY			
3/4"	10	-24	LATCH ASSY	X	YES	YES
3/4"	10	-23	LATCH ASSY	X	YES	YES
1"		-21	LATCH ASSY	X	YES	YES
3/4"		-19	LATCH ASSY	X	YES	YES
3/4"		-18	LATCH ASSY	X	YES	YES
3/4"		-17	LATCH ASSY	X	YES	YES
3/4"		-16	LATCH ASSY	X	NO	YES
3/4"		-15	LATCH ASSY	X	NO	YES
3/4"		-14	LATCH ASSY	X	YES	NO
3/4"		-13	LATCH ASSY	X	YES	NO
1"		-8	LATCH ASSY	X	YES	YES
1"		-7	LATCH ASSY	X	YES	YES
1"		-6	LATCH ASSY	X	NO	YES
1"		-5	LATCH ASSY	X	NO	YES
1"		-4	LATCH ASSY	X	YES	NO
1"		-3	LATCH ASSY	X	YES	NO
3/4" DR 1"		-2	LATCH ASSY	X	NO	NO
3/4" DR 1"		-1	LATCH ASSY	X	NO	NO

PANEL THICKNESS	PRIMARY DASH NO.	DESCRIPTION	SHOWN	OPPOSITE	KNOB & 3 ESCUTCHEONS	EMERGENCY UNLOCK ASSY		
PARTS LIST								
UNLESS OTHERWISE SPECIFIED: DIMENSIONS IN INCHES		DRWN BY	JEE	10-3-77	SKYLOCK INDUSTRIES INCORPORATED MONROVIA CALIFORNIA U. S. A.			
TOLERANCES ON DRILLED HOLES AND 10387		CHECKED	DEAN VO	12/30/98				
DECIMALS .1 .2 .3 .4 .5 .6 .7 .8 .9 1.0 1.1 1.2 1.3 1.4 1.5 1.6 1.7 1.8 1.9 2.0		ENGINEER	T. CSIK	12/31/98				
DIMENSIONS IN MILLIMETERS		MFG	P. MATSUOKA	1/6/98				
TOLERANCES ON DRILLED HOLES AND 10387		QC	J. VIVIRITO	1/12/98	LATCH ASSY, LAVATORY			
DECIMALS .1 .2 .3 .4 .5 .6 .7 .8 .9 1.0 1.1 1.2 1.3 1.4 1.5 1.6 1.7 1.8 1.9 2.0		DO NOT SCALE THIS DRAWING		USED ON			SIZE	CODE IDENT. NO.
NEXT ASSY							C	51941
MANUFACTURE IN ACCORDANCE WITH SKYLOCK IND. INC., QUALITY CONTROL MANUAL QC.001				SCALE	NONE	WT. .25 KG/. 60 LB.		
				DRAWING NO.	20252	REV. D		
				SHEET	1	OF 2		

THE INFORMATION AND DESIGN HEREIN WAS ORIGINATED BY AND IS THE PROPERTY OF SKYLOCK INDUSTRIES INCORPORATED. SKYLOCK INDUSTRIES INCORPORATED RESERVES ALL PATENT, PROPRIETARY, DESIGN MANUFACTURING, REPRODUCTION, USE AND SALES RIGHTS THERE TO, AND TO ANY ARTICLE DISCLOSED THEREIN EXCEPT TO THE EXTENT RIGHTS ARE EXPRESSLY GRANTED TO OTHERS. THE FOREGOING DOES NOT APPLY TO VENDOR PROPRIETARY PARTS.

REVISIONS				
ZONE	LTR	DESCRIPTION	DATE	APPROVED
		SEE SHT. 1 FOR NOTES		

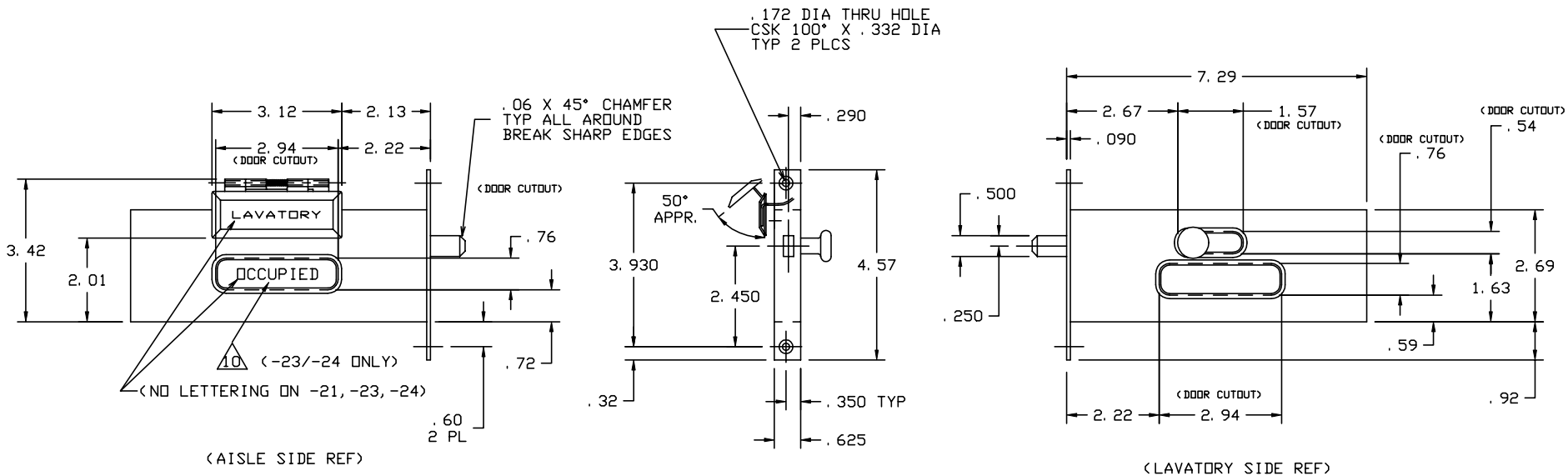

-1, -3, -5, -7, -9, -11, -13, -15, -17, -19, -21, -23 LATCH ASSY (SHOWN)
-2, -4, -6, -8, -10, -12, -14, -16, -18, -24 LATCH ASSY (OPP.)

SKYLOCK INDUSTRIES INCORPORATED
 MONROVIA CALIFORNIA U. S. A.

INDICATOR LATCH ASSY

SIZE C	CODE IDENT. NO. 51941	DRAWING NO. 20252	REV. D
SCALE 1: 2	VT. . 75 LB.	SHEET 2	OF 2