

THE INFORMATION AND DESIGN HEREIN WAS ORIGINATED BY AND IS THE PROPERTY OF SKYLARK INDUSTRIES INCORPORATED. SKYLARK INDUSTRIES INCORPORATED RESERVES ALL RIGHTS, INCLUDING DESIGN, MANUFACTURING, PATENT RIGHTS AND ALL OTHER RIGHTS AND EMPRESSESLY GRANTED TO SKYLARK. THE FOREGOING DOES NOT APPLY TO REPRODUCED PARTS.

NOTES: UNLESS OTHERWISE SPECIFIED.

1. MAT'L: HANDLE, BASE, CAM - BRASS; SHAFT - CRES.
2. FINISH: SATIN BRUSH.
3. PART NO. TO BE ETCHED ON NON-VISIBLE SURFACE OF LATCH ASSY.

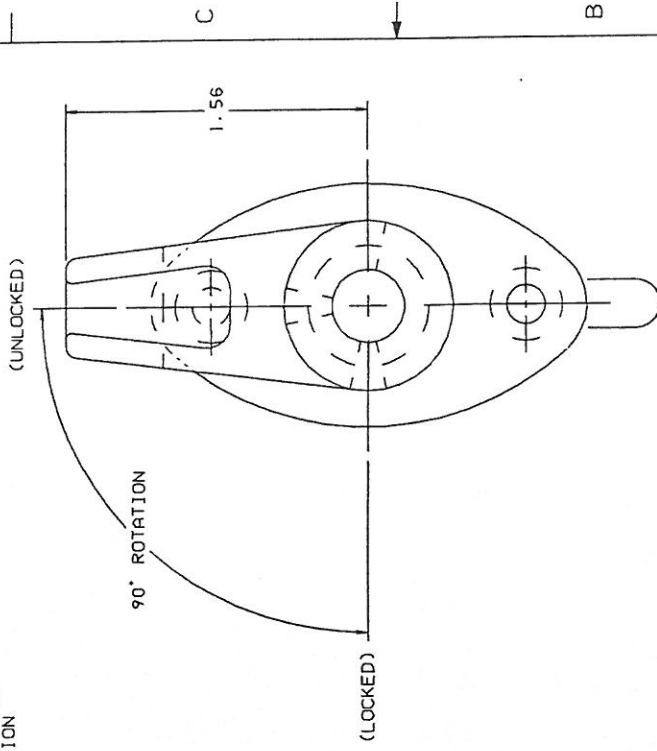
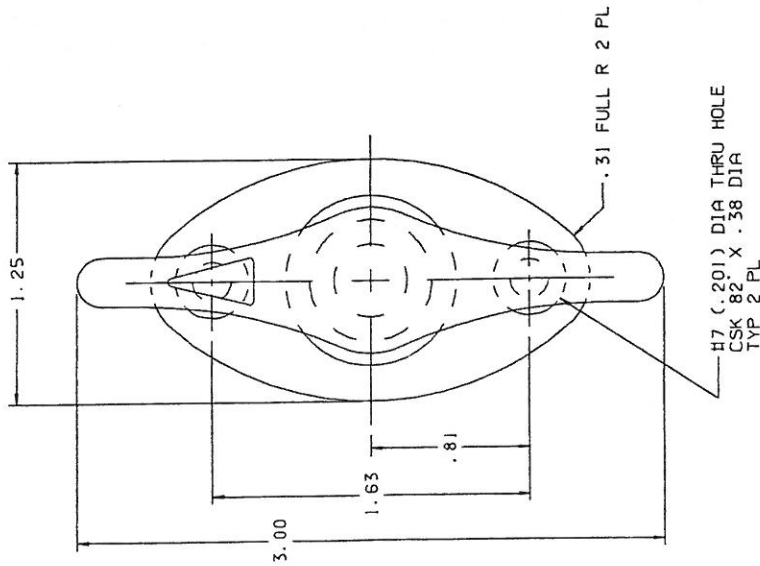
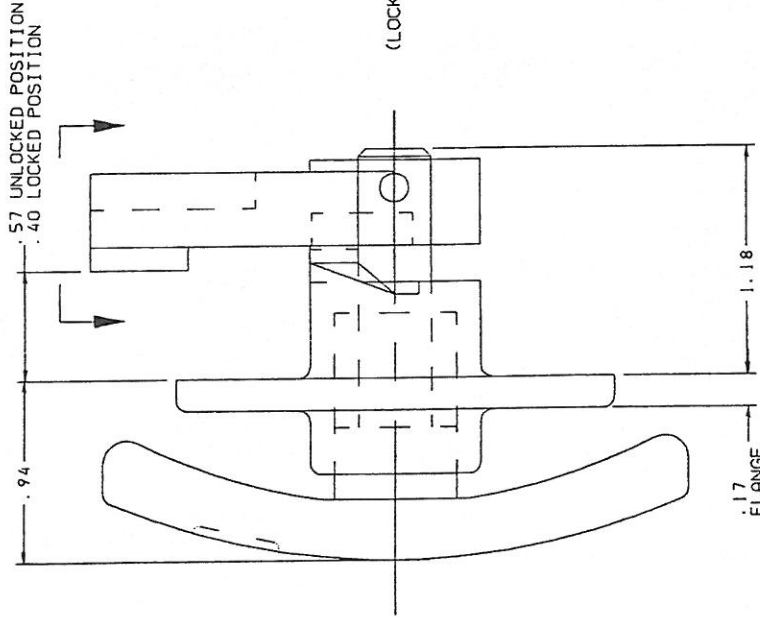
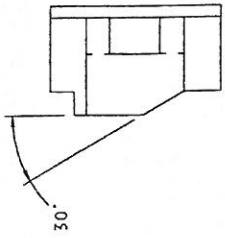

REVISIONS			
ZONE	LTR	DESCRIPTION	DATE
NC		PRODUCTION RELEASE	11-25-96
			T. CSIK

(VIA RAIL H141888)

PART NO.	-1	DESCRIPTION	DRAW LATCH
PARTS LIST			
UNLESS OTHERWISE SPECIFIED			
DIMENSIONS ARE IN INCHES			
TOLERANCES ON			
DIMENSIONS			
FRACTIONS DECIMALS ANGLES DRILLED HOLES			
.XXX .XXX .XXX .XXX .XXX .XXX .XXX .XXX			
.XXX .XXX .XXX .XXX .XXX .XXX .XXX .XXX			
.XXX .XXX .XXX .XXX .XXX .XXX .XXX .XXX			
.XXX .XXX .XXX .XXX .XXX .XXX .XXX .XXX			
DO NOT SCALE THIS DRAWING			
MATERIAL - FINISH			
NEXT ASSY			
FINAL ASSY			
DATE	11-25-96	NO. DRAWING	20932
REV.	C	SIZE	NC
SCALE	2:1	SHEET	1 OF 1



SKYLARK INDUSTRIES INCORPORATED  
HONOLULU CALIFORNIA U.S.A.

DRAW LATCH