

AVIBANK'S LINE OF PRODUCTS

**ADJUSTABLE
DIAMETER
FASTENERS**

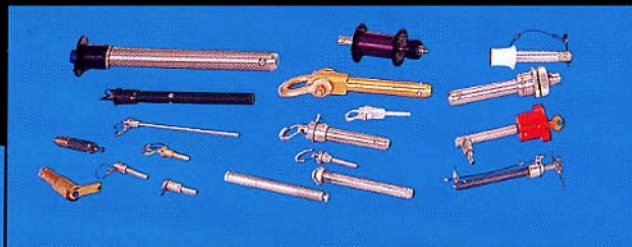

**QUICK RELEASE PINS
& ACCESSORIES**

**SELF RETAINING BOLTS
AND ACCESSORIES**

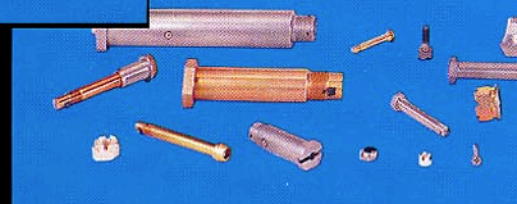

HOOK LATCHES PAGE 4

A wide variety of configurations ranging from flat to contoured, to protruding to low profile with variable load requirement, are available. Adjustable hooks or keepers compensate for wear.

FLUSH & PUSH BUTTON LATCHES PAGE 5

These latches are available in many styles which operate with a push, pull or slide trigger release. Flushness with the parent material prevents snagging or drag.

SHEAR PIN & SLIDE BOLT LATCHES PAGE 6

These latches are designed to carry shear type loads. They can be operated by sliding the pin or bolt in or out of the load-carrying area or receptacle.

PAWL LATCHES PAGE 7

These latches use a cam action to not only lock a door but also to take-up and compress the door gasket preventing electromagnetic interference.

CONTAINER, OVER-THE-CENTER & V-BAND LATCHES PAGE 7

These latches are available in various styles for cases, boxes and crates. The V-band latches incorporate folding handles that allow for a mechanical advantage during closing.

PRESSURE RELIEF LATCHES PAGE 8

These latches are normally used on engine cowls. They automatically release under a pre-determined load to release pressure on the cowlings.

THREADED INSERTS

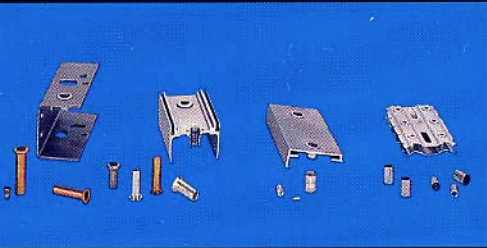

STRUCTURAL PANEL FASTENERS

STRUTS/HOLD-OPEN RODS

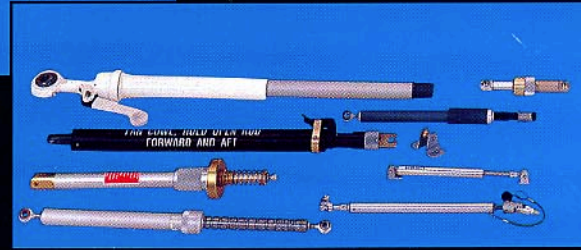

OVERHEAD BAGGAGE RACK LATCHES PAGE 8

These latches are used on commercial planes to open and close baggage compartments. Various materials, including plastic, are available.

FOLDING HANDLES PAGE 9

These handles are for electronic boxes and drawers. They fold out of the way after installation. They are also used as a carrying handle when the box or drawer is removed.

CHASSIS LATCHES & KEEPERS PAGE 9

These latches are used on electronic doors, drawers and black boxes. They combine the hold-down feature with the need to have a carrying handle. Some can be removed during flight. Keepers are also available.

HINGES & INSPECTION PLATES PAGE 10

Gooseneck hinges open the radome or door out of the way. Various style spring-loaded plates are available to allow access to areas that require inspection.

ROTARY LATCHES PAGE 10

Flush mounted rotary latches are usually actuated with a tool. The internal eccentric cam design allows tension take-up. A warning flag indicates whether the latch is locked or unlocked.

KEEPERS & EYEBOLTS PAGE 11

Adjustable or non-adjustable keepers or eyebolts are mated with a hook or a rotary latch. These keepers are adjusted to apply the correct preload.

SEE PAGES 12-14 FOR APPLICATION SHEETS

HOOK LATCHES



9479



9589

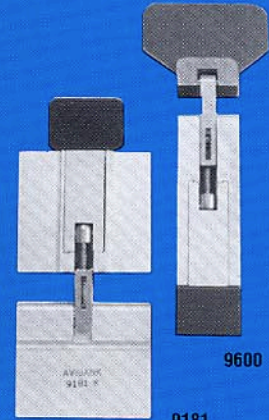

9600

9181

- ◆ FLAT OR CONTOURED CONFIGURATIONS
- ◆ ADJUSTABLE HOOKS TO COMPENSATE FOR WEAR AND ADJUST LATCH PRELOAD
- ◆ STANDARD DESIGNS TO WITHSTAND UP TO 15,000 LBS. ULTIMATE TENSION
- ◆ HANDLE OPENS FREELY APPROXIMATELY 15° TO MAKE IT EASY TO GRIP AND OPEN WITHOUT USING A TOOL
- ◆ SOME LATCHES HAVE A SLOT FOR A SCREW DRIVER TO OPERATE THE HANDLE
- ◆ LATCHES HAVE A TRIGGER AS A SECONDARY LOCKING FEATURE IN ADDITION TO THE PRIMARY OVER-THE-CENTER HOOK MECHANISM
- ◆ TRIGGER HAS DOUBLE-TORSION SPRING AS A FAIL-SAFE FEATURE
- ◆ LOW PROFILE LATCHES WITH HIGH TENSION LOAD OVER 20,000 LBS. ARE ALSO AVAILABLE
- ◆ SOME LATCHES HAVE SECONDARY SAFETY FEATURES THAT ALLOW THE HANDLE TO BE CLOSED ONLY WHEN THE LATCH IS ENGAGED WITH MATING KEEPER
- ◆ EASY IDENTIFICATION OF UNLATCHED CONDITION

SEE PAGE 12 FOR APPLICATION DESIGN FORM

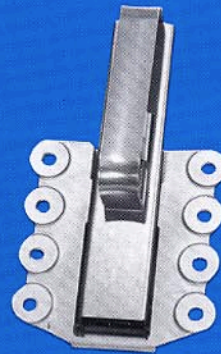

9913

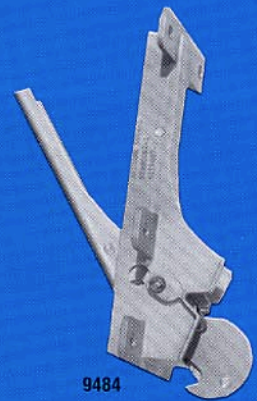

9484



9130



9093



9454



9348

9564

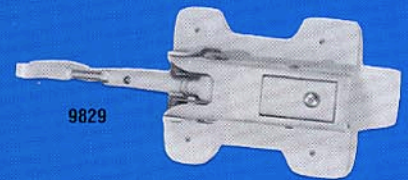

9829



9225

FLUSH AND PUSH BUTTON LATCHES

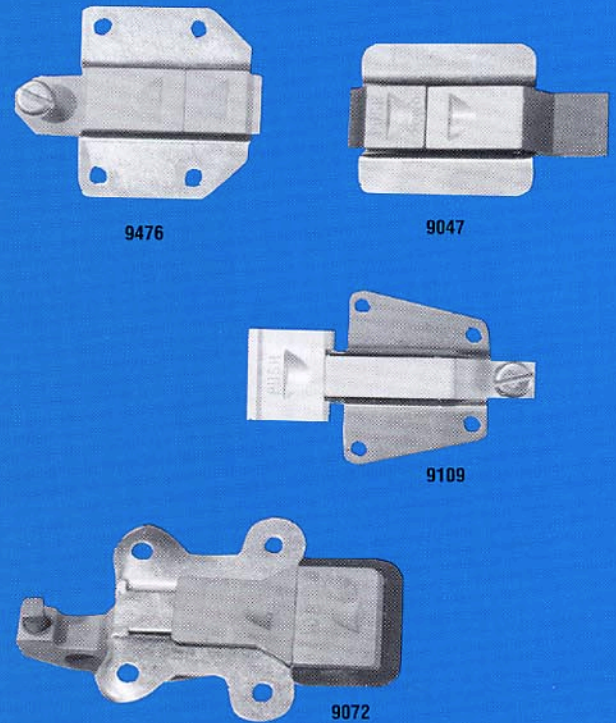
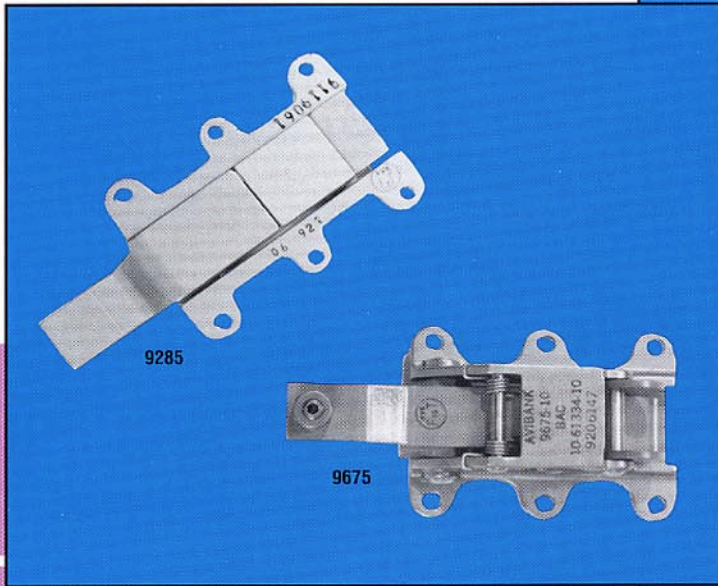

- ◆ CONTOURED FOR FLUSH FIT
- ◆ EASY-TO-USE LEVER ACTIONS
- ◆ EASY IDENTIFICATION OF UNLATCHED CONDITION
- ◆ MICRO SWITCHES CAN BE ADDED
- ◆ BOLT OFFSET CAN BE ADJUSTED FOR DIFFERENT PANEL THICKNESS
- ◆ BOLT HAS DOUBLE TORSION SPRING AS A FAIL-SAFE FEATURE
- ◆ MANY COMBINATIONS OF BOLT & TRIGGER OFFSETS ARE AVAILABLE

SEE PAGE 12 FOR APPLICATION DESIGN FORM

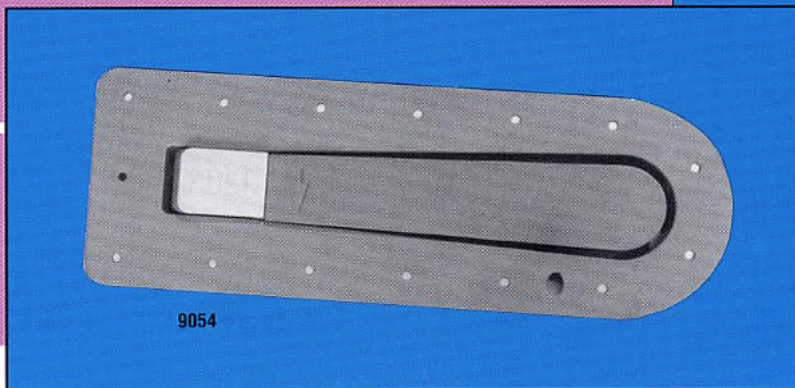
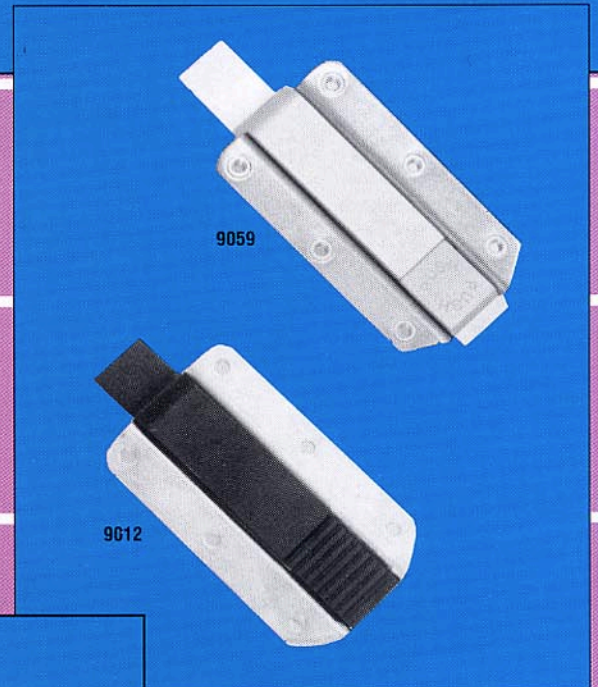

SHEAR PIN AND SLIDE BOLT LATCHES

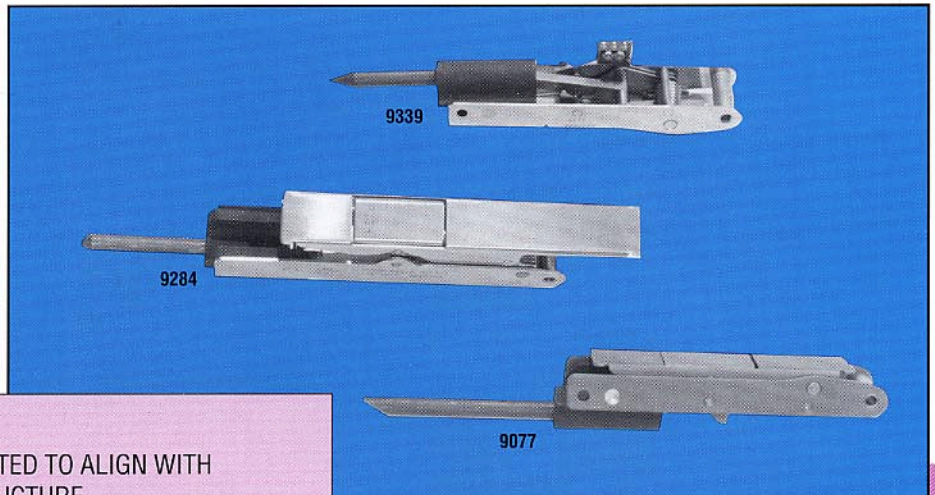

- ◆ PIN ANGLE CAN BE ADJUSTED TO ALIGN WITH MATING HOLE IN THE STRUCTURE
- ◆ HANDLE OPENS FREELY 15° FOR EASY ACCESS FOR UNLOCKING
- ◆ LATCH HAS A TRIGGER AS A SECONDARY LOCKING FEATURE
- ◆ TRIGGER HAS DOUBLE TORSION SPRING AS A FAIL-SAFE FEATURE
- ◆ MICRO SWITCHES CAN BE ADDED AS A VISUAL INDICATOR THAT THE LATCH IS UNLOCKED OR LOCKED
- ◆ ON LARGE PANELS, SHEAR PIN LATCHES ARE USUALLY USED IN CONJUNCTION WITH HOOK LATCHES
- ◆ PIN PROVIDES ADDED STRENGTH IN SHEAR APPLICATIONS
- ◆ TAPERED PIN ALLOWS EASY ALIGNMENT WITH MATING HOLE
- ◆ A VISIBLE PAINTED HANDLE INDICATES WHEN LATCH IS UNLOCKED

SEE PAGE 13 FOR APPLICATION DESIGN FORM

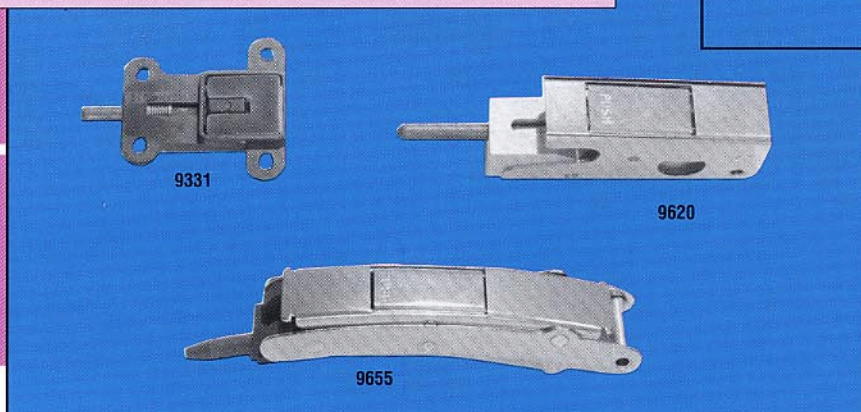
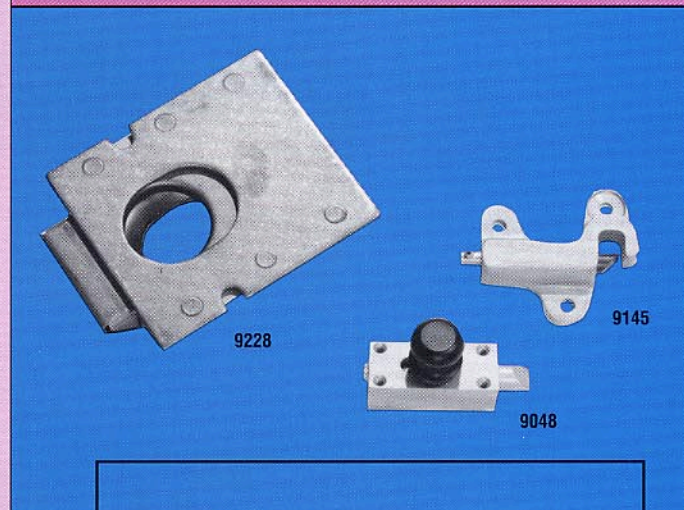

PAWL LATCHES

- ◆ QUICK ENGAGEMENT AND RELEASE WITH ROTATING PAWL
- ◆ PAWL TURNS AND DRAWS UP THE PANEL/DOOR
- ◆ TAKE-UP COMPRESSES THE DOOR GASKET
- ◆ PROVIDE ADDED PROTECTION AGAINST EMI/RFI BY TAKE-UP AGAINST CABINET STRUCTURE

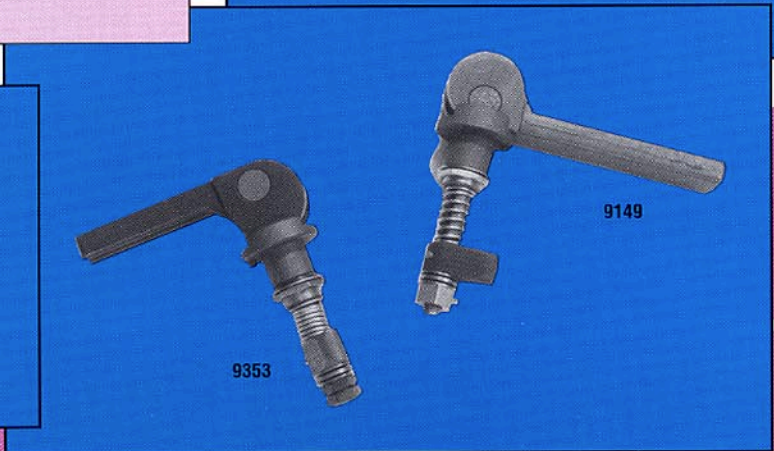
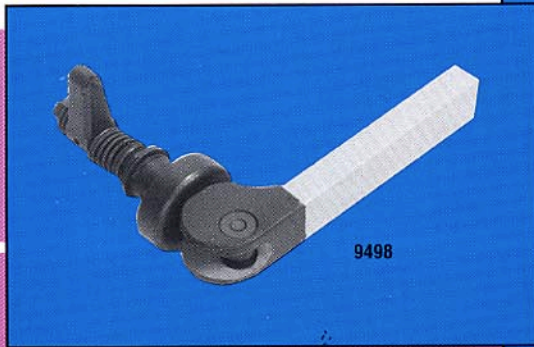
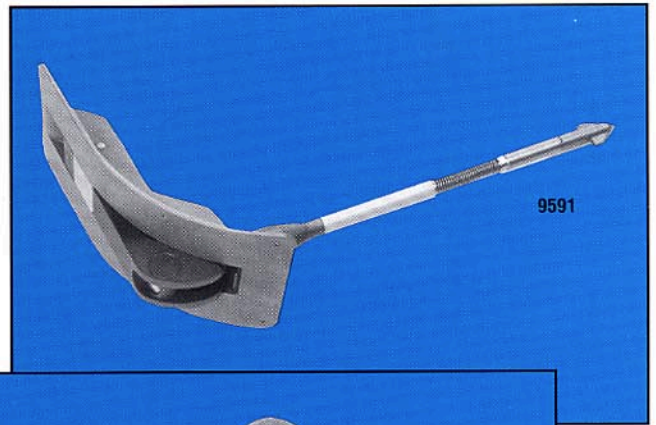

CONTAINER, OVER-THE-CENTER & V-BAND LATCHES

- ◆ PRODUCE HIGH PRELOAD WITH LONG HANDLE LEVERAGE
- ◆ TRIGGER HAS DOUBLE TORSION SPRING AS A FAIL-SAFE FEATURE
- ◆ T-BOLT IS ADJUSTABLE FOR PROPER PRELOAD OR ENGAGEMENT
- ◆ SECONDARY SAFETY FEATURE ALLOWS THE HANDLE TO CLOSE ONLY WHEN THE LATCH IS ENGAGED WITH MATING KEEPER

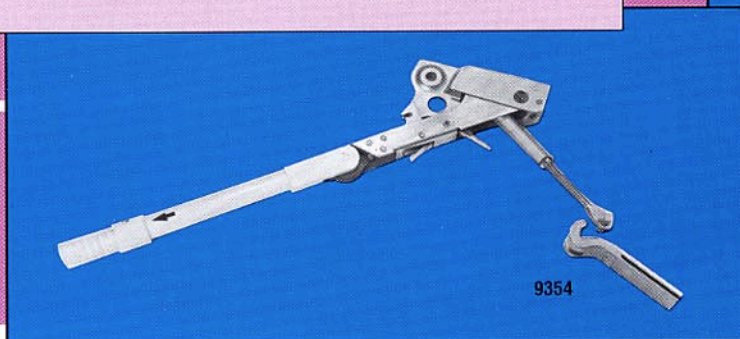
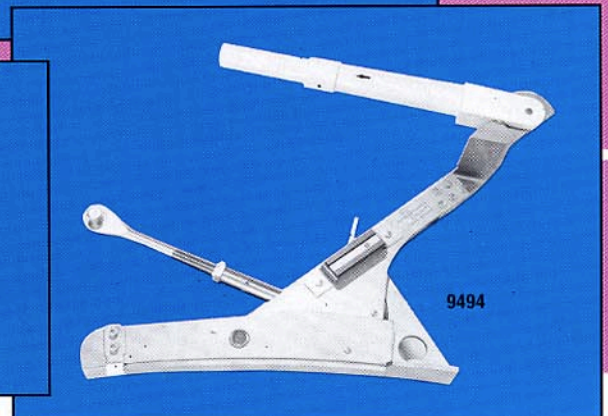
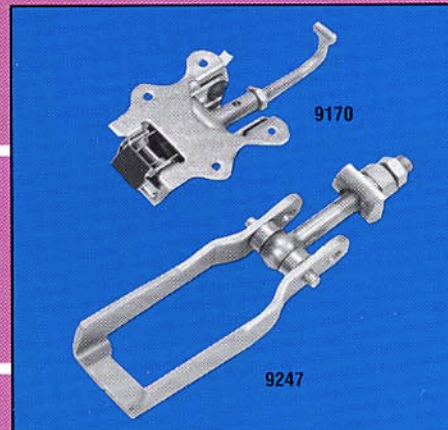

PRESSURE RELIEF LATCHES

- ◆ ACTUATE WITH A STANDARD SCREW DRIVER
- ◆ PRE-SET LOADS AT THE FACTORY TO HANDLE PRECISE LOADS WITHIN $\pm 10\%$ OF LOAD TOLERANCE
- ◆ LATCHES ALLOW BLEED-OFF OF EXCESSIVE PRESSURES TO PREVENT DAMAGE TO VITAL INTERNAL HARDWARE

SEE PAGE 13 FOR APPLICATION DESIGN FORM

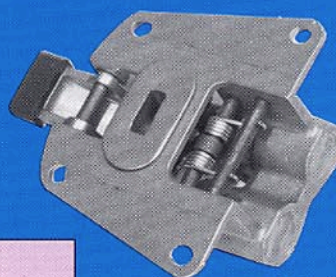

9483

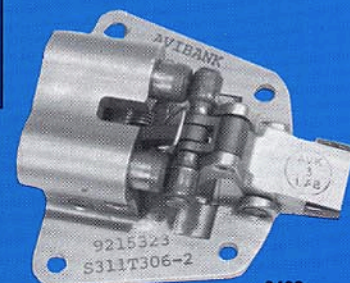

9488

OVERHEAD BAGGAGE-RACK LATCHES

- ◆ SOME LATCHES HAVE INTERLOCK SYSTEM WITH HOOK DESIGN TO WITHSTAND HIGH LOADS AND VIBRATION
- ◆ PROVIDES PASSENGERS A STORAGE COMPARTMENT THAT IS EASY TO OPEN AND SECURES TIGHTLY TO PREVENT OPENING DURING FLIGHTS
- ◆ EASY ATTACHMENT OF BAGGAGE BIN TO BULKHEAD



9877



9877



9145

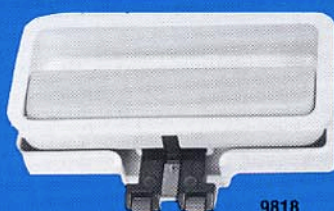

9818



9819

FOLDING HANDLES

- ◆ LIGHTWEIGHT DESIGNS OF ALUMINUM AND TITANIUM MATERIAL
- ◆ UP TO 3 POSITIVE HANDLE LOCKING POSITIONS IF REQUIRED
- ◆ WITHSTAND HIGH SIDE LOAD TO THE HANDLE IN CASE OF MISHANDLING OR ACCIDENT
- ◆ HANDLE FOLDS AWAY TO PREVENT SNAGGING OR INADVERTENT RELEASE
- ◆ HANDLE IS USED FOR CARRYING ELECTRONIC BOX WHEN REMOVED FROM THE APPLICATION

SEE PAGE 14 FOR APPLICATION DESIGN FORM

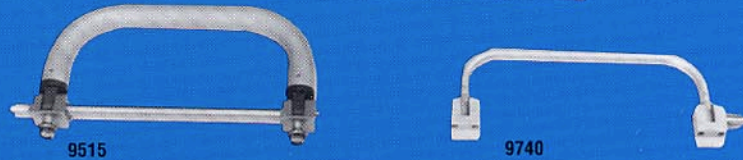
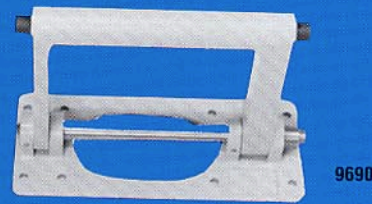

CHASSIS LATCHES AND KEEPERS

- ◆ THESE LATCHES COMBINE THE FOLD-DOWN FEATURE WITH THE NEED TO HAVE A CARRYING HANDLE
- ◆ LIGHTWEIGHT ALUMINUM DESIGN LATCH
- ◆ KEEPERS WITH DIFFERENT COMBINATION OF LOAD AND COMPENSATING TRAVEL ARE AVAILABLE

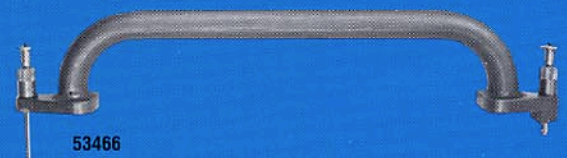
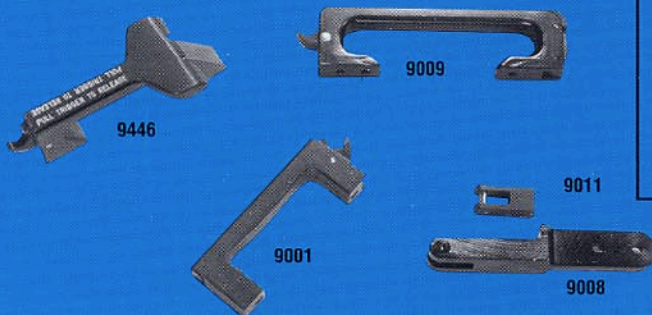

HINGES AND INSPECTION PLATES

- ◆ PROVIDES ACCESSIBILITY TO AREAS WHERE INSPECTION IS REQUIRED
- ◆ TRIGGER-LOCKED HINGES ALLOW DOORS AND PANELS TO SWING COMPLETELY OUT OF THE WAY TO ALLOW WORK IN COMPARTMENT



9316

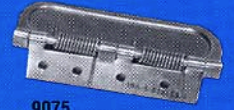

9075



53558

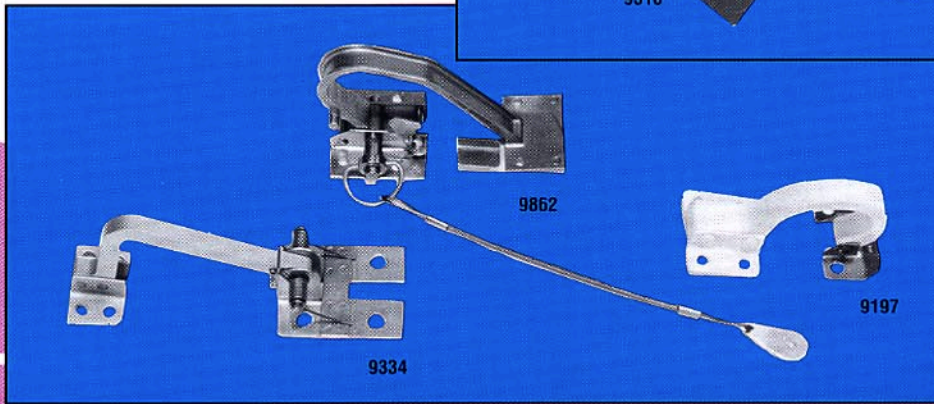

9334

9862

9197

ROTARY LATCHES

- ◆ SMALL CUT-OUT HOLE IN THE PANEL PROVIDES GOOD FLUSHNESS
- ◆ PAINTED VISUAL INDICATOR WILL POP UP WHEN LATCH IS NOT ENGAGED
- ◆ FLUSH MOUNTED
- ◆ ACTIVATED WITH A STANDARD TOOL
- ◆ PROVIDES TENSION TAKE-UP WHEN CLOSED
- ◆ NO SPECIAL TOOLS REQUIRED FOR PANEL PREPARATION

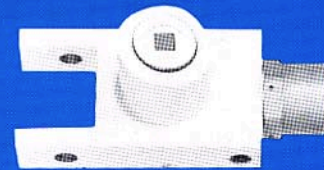

9183



9026

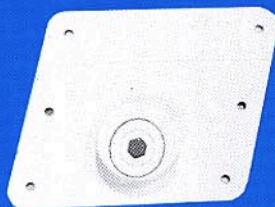

9350

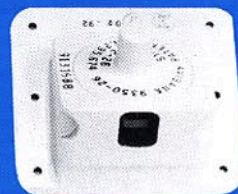

9350

KEEPERS AND EYEBOLTS

9357

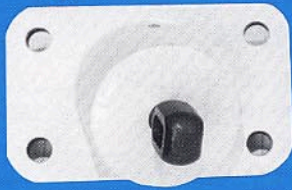

9350

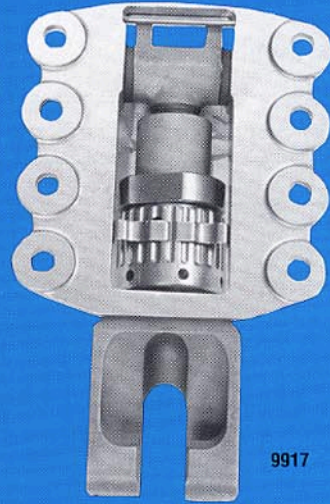

9917

- ◆ ADJUSTABLE KEEPER CAN BE ADJUSTED TO PROVIDE PROPER TENSION LOAD TO THE LATCH WHILE IT IS STILL ENGAGED
- ◆ SLOTTED HOLES IN MOUNTING PLATE ALLOW ADJUSTMENT
- ◆ AVAILABLE IN ADJUSTABLE OR NON-ADJUSTABLE TYPES
- ◆ ADJUSTABLE TYPES ARE FOR APPLYING CORRECT PRELOAD TO LATCHES
- ◆ SPECIAL KEEPER HOUSINGS ARE AVAILABLE FOR MOUNTING

SEE PAGE 14 FOR APPLICATION DESIGN FORM

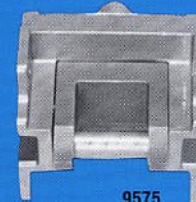

9575



9782

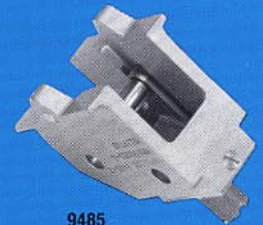

9485



9183

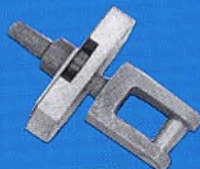

9351



9929



9381



9382

HOOK LATCHES (SEE PAGE 4)

CONTROL ENVELOPE DIMENSIONS

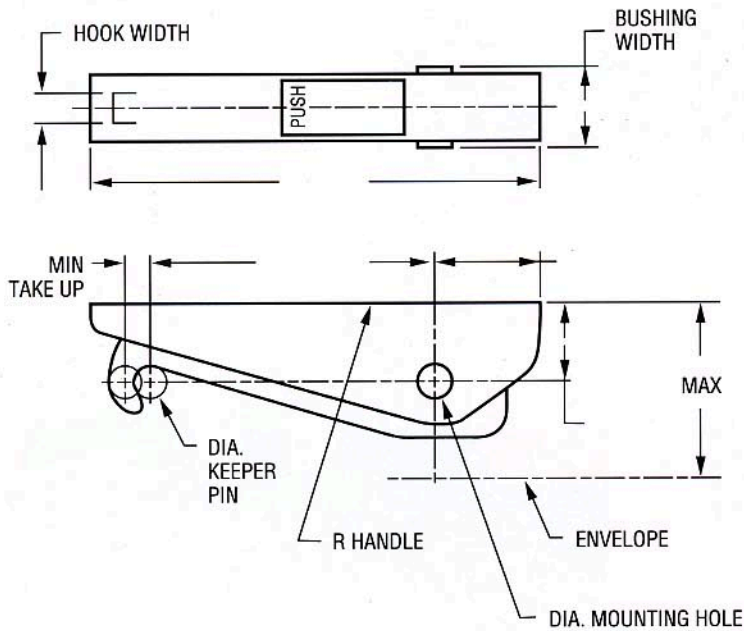

DATA

1. ULTIMATE LOAD _____ LBS.
2. LIMIT LOAD _____ LBS.
3. PRELOAD _____ LBS.
4. FATIGUE LIFE _____ CYCLES
_____ LBS. MIN. _____ LBS. MAX.
5. OPERATING TEMPERATURE _____ °F
6. MATERIAL _____
7. FINISH _____

COMMENTS: _____

COMPANY _____
 ADDRESS _____
 CITY _____
 STATE _____ ZIP _____
 NAME _____
 PHONE NO. _____
 FAX NO. _____

FLUSH LATCHES (SEE PAGE 5)

CONTROL ENVELOPE DIMENSIONS

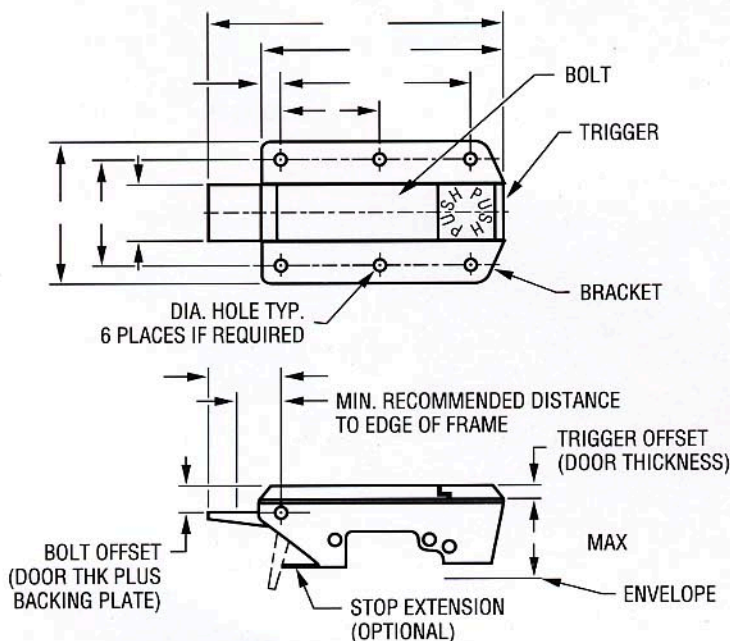

DATA

1. ULTIMATE LOAD _____ LBS.
2. OPERATING TEMPERATURE _____ °F
3. MATERIAL _____
4. FINISH _____

COMMENTS: _____

COMPANY _____
 ADDRESS _____
 CITY _____
 STATE _____ ZIP _____
 NAME _____
 PHONE NO. _____
 FAX NO. _____

SHEAR PIN LATCHES (SEE PAGE 6)

CONTROL ENVELOPE DIMENSIONS

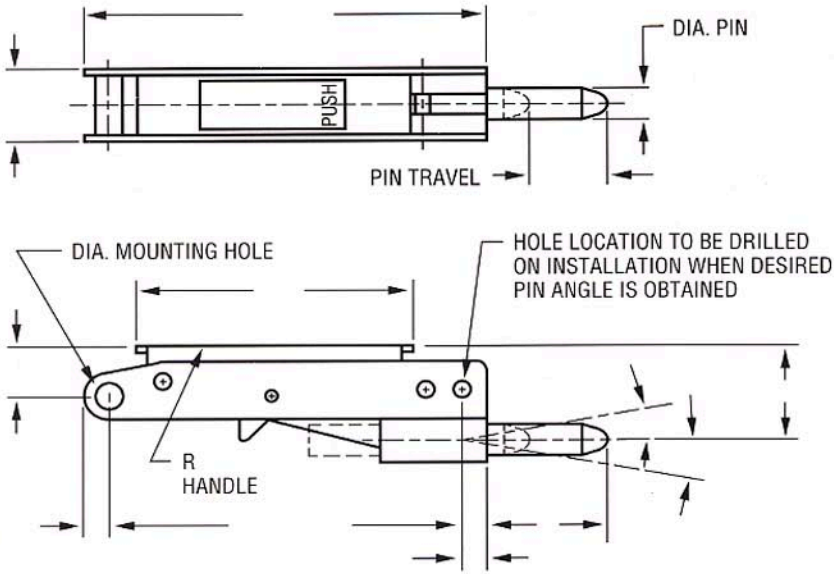

DATA

1. DOUBLE SHEAR LOAD _____ LBS.
SINGLE SHEAR LOAD _____ LBS.
2. OPERATING TEMPERATURE _____ °F
6. MATERIAL _____
7. FINISH _____

COMMENTS: _____

COMPANY _____
 ADDRESS _____
 CITY _____
 STATE _____ ZIP _____
 NAME _____

 PHONE NO. _____
 FAX NO. _____

PRESSURE RELIEF LATCHES (SEE PAGE 8)

CONTROL ENVELOPE DIMENSIONS

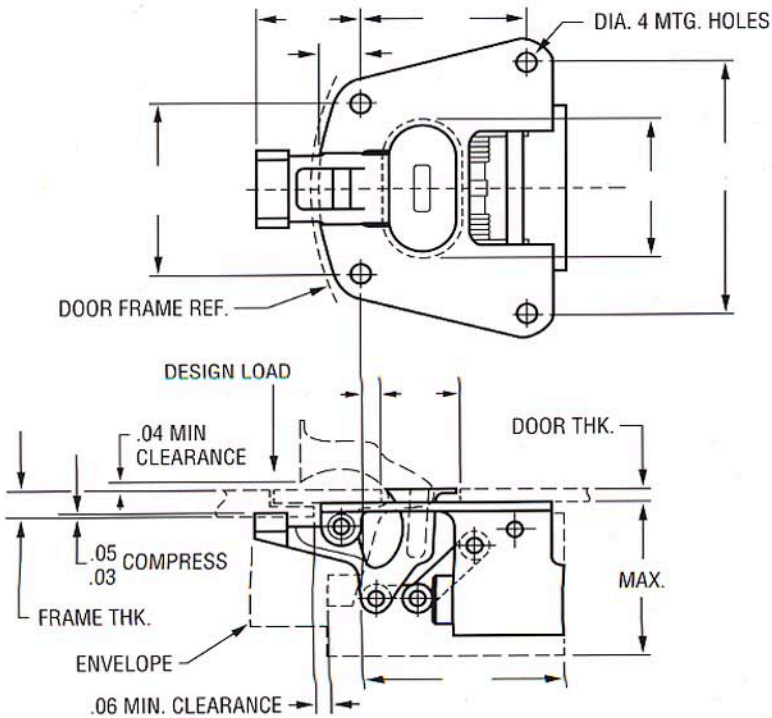

DATA

1. DESIGN LOAD _____ LBS.
± _____ LBS.
2. OPERATING TEMPERATURE _____ °F
3. MATERIAL _____
4. FINISH _____

COMMENTS: _____

COMPANY _____
 ADDRESS _____
 CITY _____
 STATE _____ ZIP _____
 NAME _____

 PHONE NO. _____
 FAX NO. _____

FOLDING HANDLES (SEE PAGE 9)

CONTROL ENVELOPE DIMENSIONS

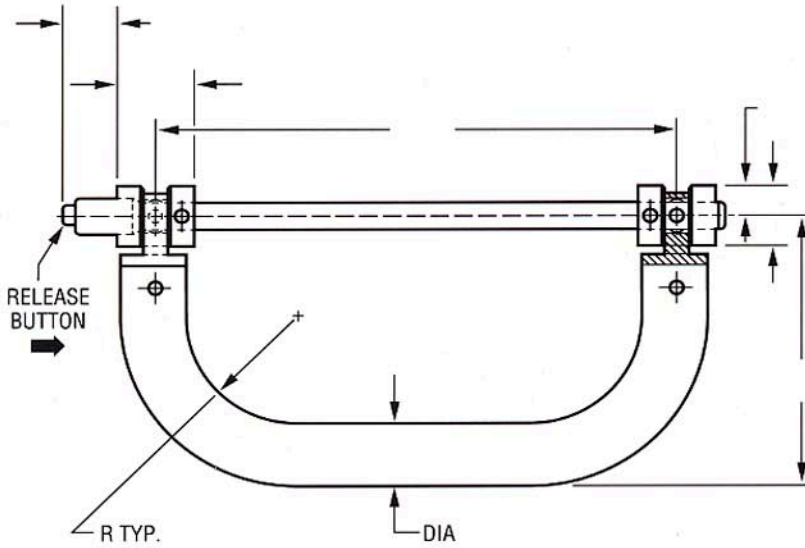

DATA

1. HANDLE TO WITHSTAND SIDE LOAD OF _____ LBS.
2. OPERATING TEMPERATURE _____ °F
3. MATERIAL _____
4. FINISH _____

COMMENTS: _____

COMPANY _____
 ADDRESS _____
 CITY _____
 STATE _____ ZIP _____
 NAME _____

 PHONE NO. _____
 FAX NO. _____

KEEPERS & EYEBOLTS (SEE PAGE 11)

CONTROL ENVELOPE DIMENSIONS

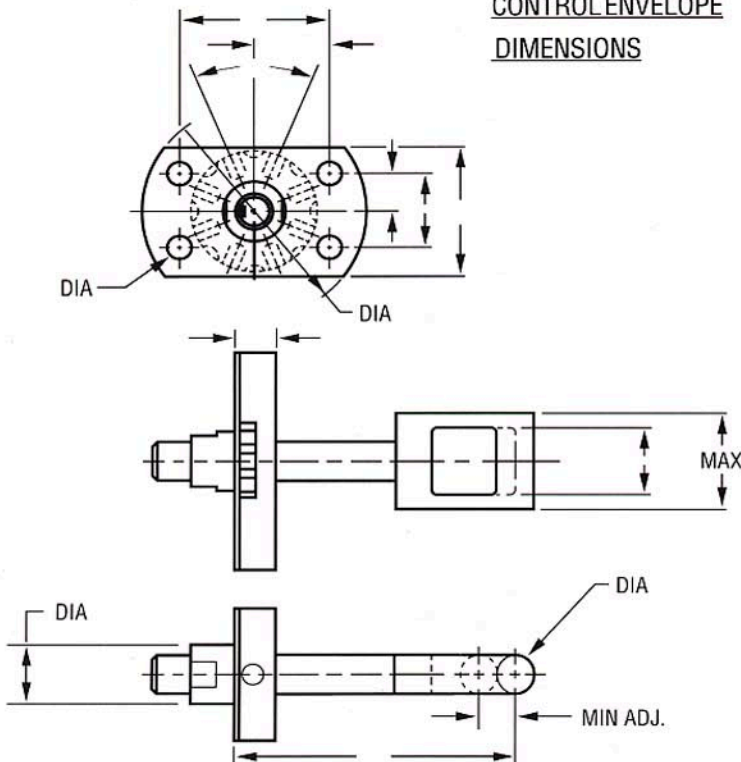

DATA

1. ULTIMATE LOAD _____ LBS.
1. FATIGUE LIFE _____ CYCLES
 _____ LBS. MIN. FOR _____ LBS. MAX.
2. OPERATING TEMPERATURE _____ °F
3. MATERIAL _____
4. FINISH _____

COMMENTS: _____

COMPANY _____
 ADDRESS _____
 CITY _____
 STATE _____ ZIP _____
 NAME _____

 PHONE NO. _____
 FAX NO. _____