

ADJUSTABLE DIAMETER FASTENERS

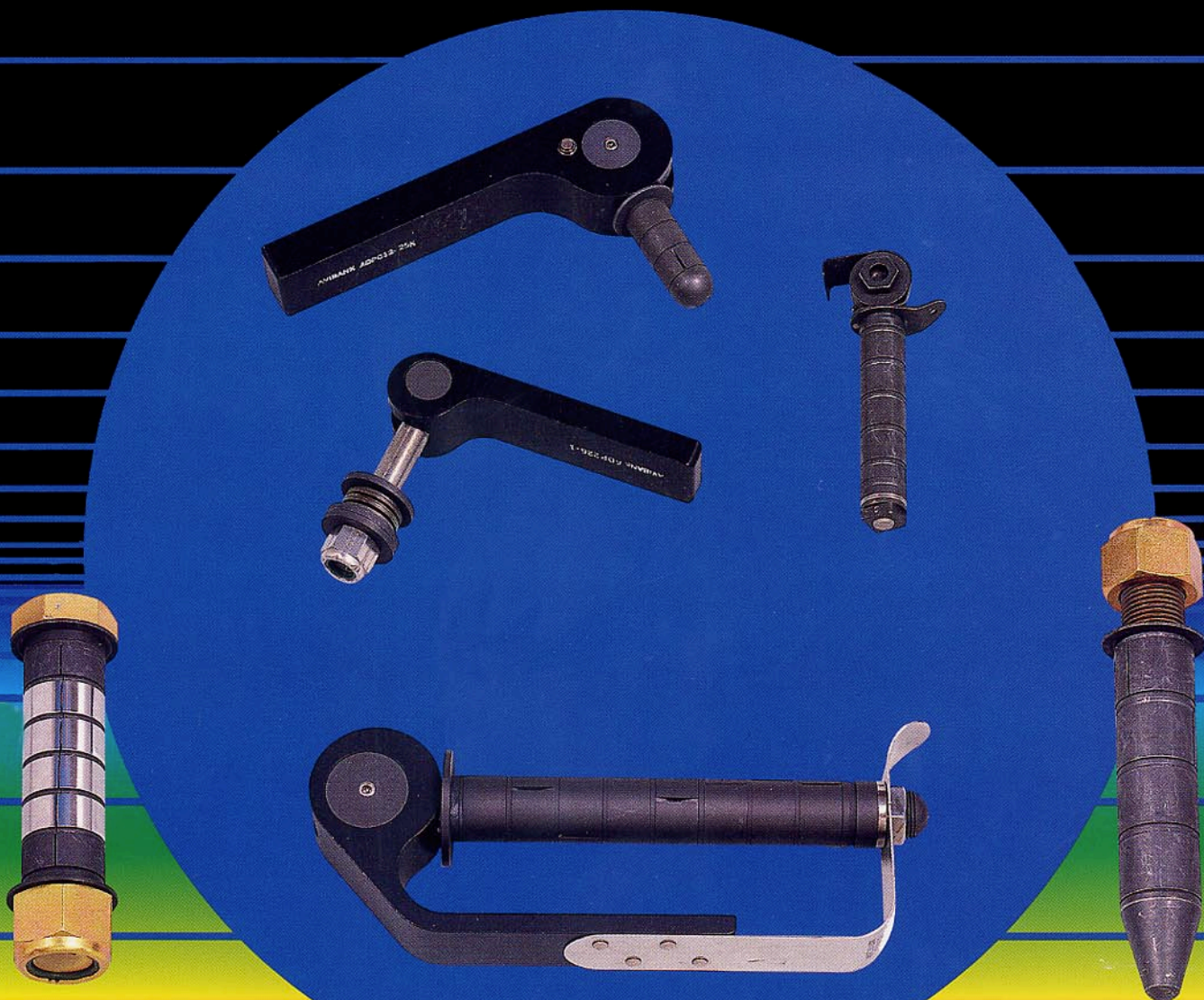

AVIBANK
MFG. INC.

AVIBANK'S LINE OF PRODUCTS

THREADED INSERTS

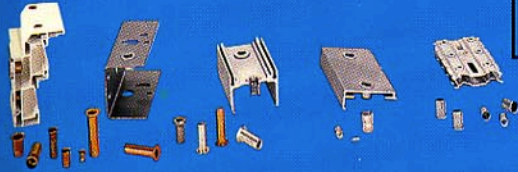

QUICK RELEASE PINS & ACCESSORIES

SELF-RETAINING BOLTS AND ACCESSORIES



ADJUSTABLE DIAMETER PINS

PAGES 4-5

AVIBANK's Adjustable Diameter Pins are easily installed and removed without the use of any tools.

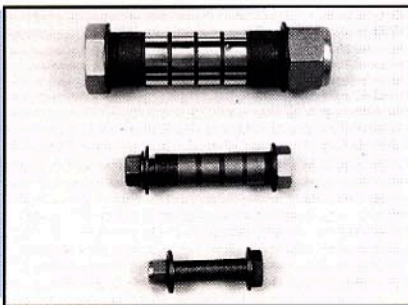

ADJUSTABLE DIAMETER BOLTS

PAGES 6-7

AVIBANK's Adjustable Diameter Bolts can be easily installed and removed in the same manner as a standard solid bolt.

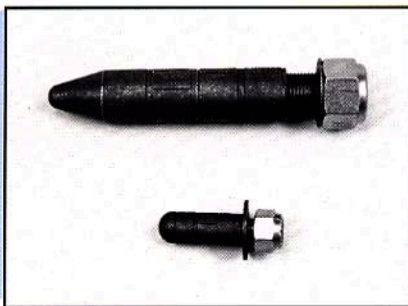

ADJUSTABLE DIAMETER BLIND BOLTS

PAGES 8-9

AVIBANK's Adjustable Diameter Blind Bolts are easily installed and removed from one side only with the use of standard tools such as an allen wrench and torque wrench.

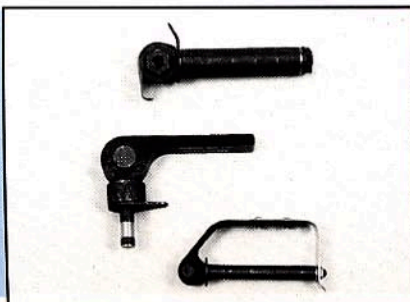

ADJUSTABLE DIAMETER SPECIALS

PAGES 10

AVIBANK's Adjustable Diameter Specials have been developed to be used in critical applications such as helicopter blade attachments and as engine mount pins/bolts. We specialized in design and manufacturing of special designs. Send us your requirements for review.

STRUTS/HOLD-OPEN RODS

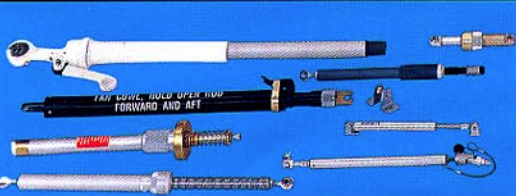

STRUCTURAL PANEL FASTENERS

LATCHES & KEEPER ASSEMBLIES

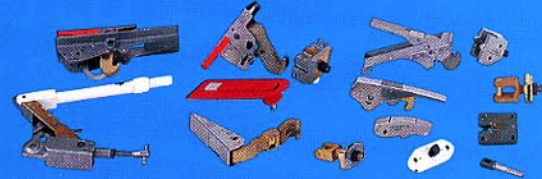

ADJUSTABLE DIAMETER FASTENERS

FEATURES

- ◆ ELIMINATES OR REDUCES WEAR DUE TO VIBRATION
- ◆ CAN BE USED IN BLIND APPLICATIONS
- ◆ PROVIDES NEAR PERFECT ALIGNMENT OF HOLES
- ◆ PERMITS A MEANS OF QUICK INSTALLATION AND REMOVAL, SOME WITHOUT TOOLS AND OFTEN WITH STANDARD TOOLS IN THE SAME MANNER AS A SOLID BOLT
- ◆ PROVIDES HIGH SHEAR STRENGTH COMPARABLE TO A SOLID BOLT
- ◆ ELIMINATES PLAY BETWEEN FASTENER AND STRUCTURE
- ◆ INTERFERENCE FIT CAPABILITIES WITH COMMERCIAL HOLE TOLERANCE
- ◆ METRIC SIZES AVAILABLE

APPLICATIONS

- ◆ QUICK CHANGE OF HELICOPTER ROTOR BLADES
- ◆ ALIGNMENT OF JET ENGINE SECTIONS
- ◆ ATTACHMENT OF EXTERNAL MUNITIONS TO AIRCRAFT/HELICOPTERS
- ◆ ALIGNMENT OF JIGS AND FIXTURES
- ◆ QUICK INSTALLATION AND REMOVAL OF AIRCRAFT ENGINES
- ◆ ATTACHMENT OF GUN SIGHTS
- ◆ ATTACHMENT OF TEST EQUIPMENT
- ◆ QUICK RELEASE AXLES FOR WHEELCHAIRS
- ◆ REPLACEMENT FOR PRESS FIT OR TAPER PINS

SEE INSIDE BACK COVER FOR APPLICATION DESIGN FORM

AVIBANK SPECIAL REQUESTS

COPY AND FILL OUT THIS FORM TO SUBMIT YOUR SPECIAL REQUIREMENTS FOR REVIEW.

ADJUSTABLE DIAMETER FASTENERS

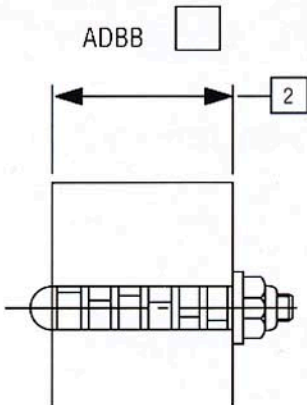
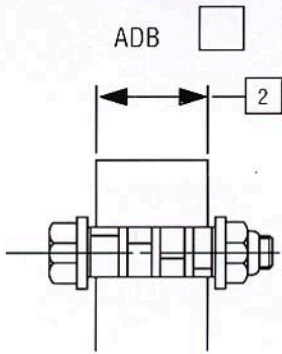
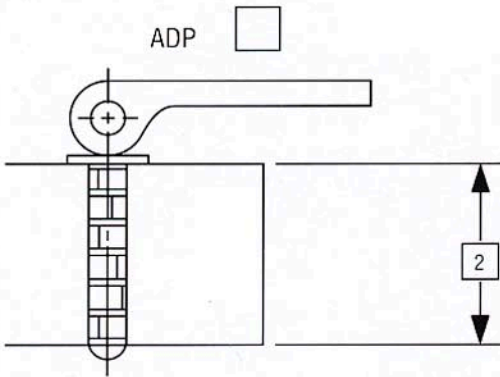

NOTES:

1. CHOOSE TYPE OF FASTENER DESIRED. CHECK ONE BOX
2. GRIP LENGTH OR STRUCTURE LENGTH.
3. FILL IN INFORMATION FOR APPLICATION AND DRAW STRUCTURE.
4. CAUTION: ALL EXPANDING SEGMENTS MUST BE CONTAINED WITHIN THE APPLICATION. IF EXPANSION IS NOT REQUIRED ON THE PART OF THE FASTENER, PLEASE INDICATE.
5. IF POSSIBLE, ATTACH A SKETCH OR DRAWING OF THE APPLICATION AND NOTE THE LENGTH AND THE DIAMETERS.

HOLE DIA.: _____

GRIP LENGTH OR
STRUCTURE LENGTH: _____

FASTENER MAT'L: _____

SHEAR LOAD: _____

TENSILE LOAD: _____

STRUCTURE MAT'L: _____

TEMPERATURE: _____

VIBRATION: _____

OTHER: _____

COMMENTS: _____

CUSTOMER NAME: _____ DATE: _____

ADDRESS: _____

PHONE: _____



AVIBANK
MFG. INC.